

Grey water tanks

Grey water tank with Europump Auto pump

It centralizes all drains (shower, sink, kitchen, toilet, etc.). Quick inspection snap cover. Fitted with removable strainer.

Code	Pumps	V	Current draw A	Max flow l/min	Max head m	Outlet mm	Inlet mm
16.130.12	16.124.03	12	3.0	48	3	19	19/25/29/38
16.130.24	16.124.04	24	1.6	48	3	19	19/25/29/38



OSCOLATI

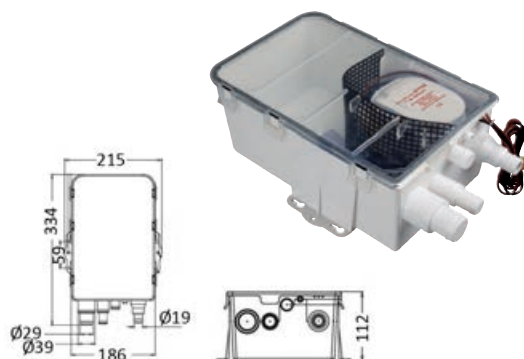

WHALE grey water tank with automatic pump

Designed to collect waste water from shower trays and sinks, then it automatically triggers the electronic field sensor to activate the pump. Clear plastic lid for easy inspection, it opens without tools. Large stainless steel mesh strainer. Easy installation: multiple inlet port sizes for easy connection to existing plumbing (only 2 wires to connect).

Code	Pumps	Sensor	V	Current draw A	Max flow l/min	Flow at 1 m l/min	Max head m	Ø inlets mm	Ø drains mm	mm
16.117.50	Orca 500 (16.550.12)	Sensor Field	12	1.5	32	16	3	19-25-28-38	19 - 25	346 x 217 x 130

Whale®

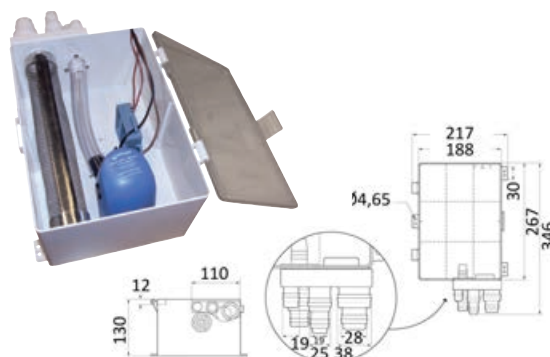

ATTWOOD grey water tank with automatic pump

attwo

Designed to centralize all drains (showers, sinks, kitchens, bathrooms, etc). Fitted with check valve to prevent bad odours. Quick inspection snap cover.

Code	Pumps	V	Current draw A	Max flow l/min	Max head m	Box capacity	Inlet mm	Outlet mm	Box mm
16.413.73	automatic Sahara 500	12	1.4	27	2.1	standard	19	19+19/25+29/37	266x206x113h
16.413.74	automatic Sahara 750	12	2.5	41	3	large	19	19+19/25+29/37	330x186x111h
16.413.75	automatic Sahara 750	24	1.3	41	3	large	19	19+19/25+29/37	330x186x111h



▲ 16.413.73

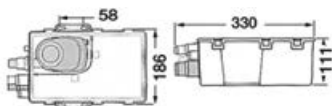

▲ 16.413.74-75

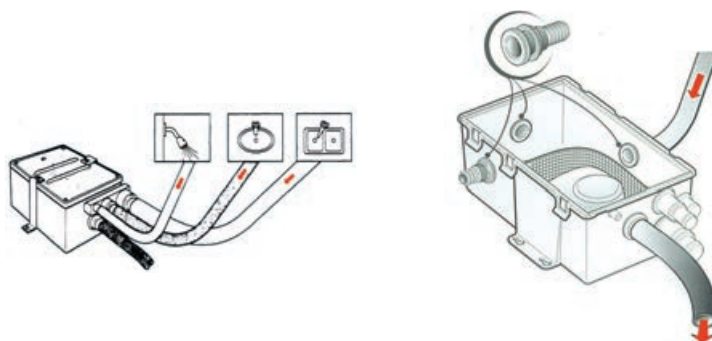

RULE shower drain system

Fitted with grey water tray/strainer. It automatically turns on when the tray is full of water.

Code	RULE code	V	Current draw A	Flow l/min	No of inlets	Inlet fittings included	Drain mm
16.117.64	98B	12	3.5	55	3	2 x 19 mm; 1 x 25 mm; 1 x 29 mm	19
16.117.65	98B - 24	24	1.8	55	3	2 x 19 mm; 1 x 25 mm; 1 x 29 mm	19

rule®

